

ASUS ProArt

# ProArt PA401

---

USER GUIDE

---

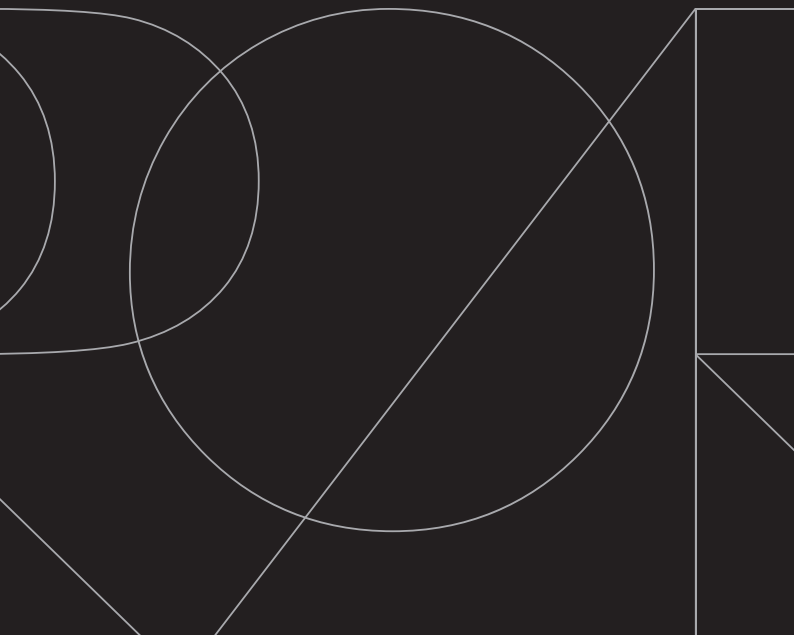

**Copyright © 2024 ASUSTeK Computer Inc.  
All Rights Reserved.**

No part of this manual, including the products and software described in it, may be reproduced, transmitted, transcribed, stored in a retrieval system, or translated into any language in any form or by any means, except documentation kept by the purchaser for backup purposes, without the express written permission of ASUSTeK Computer Inc. ("ASUS").

Product warranty or service will not be extended if: (1) the product is repaired, modified or altered, unless such repair, modification or alteration is authorized in writing by ASUS; or (2) the serial number of the product is defaced or missing.

ASUS PROVIDES THIS MANUAL "AS IS" WITHOUT WARRANTY OF ANY KIND, EITHER EXPRESS OR IMPLIED, INCLUDING BUT NOT LIMITED TO THE IMPLIED WARRANTIES OR CONDITIONS OF MERCHANTABILITY OR FITNESS FOR A PARTICULAR PURPOSE. IN NO EVENT SHALL ASUS, ITS DIRECTORS, OFFICERS, EMPLOYEES OR AGENTS BE LIABLE FOR ANY INDIRECT, SPECIAL, INCIDENTAL, OR CONSEQUENTIAL DAMAGES (INCLUDING DAMAGES FOR LOSS OF PROFITS, LOSS OF BUSINESS, LOSS OF USE OR DATA, INTERRUPTION OF BUSINESS AND THE LIKE), EVEN IF ASUS HAS BEEN ADVISED OF THE POSSIBILITY OF SUCH DAMAGES ARISING FROM ANY DEFECT OR ERROR IN THIS MANUAL OR PRODUCT.

SPECIFICATIONS AND INFORMATION CONTAINED IN THIS MANUAL ARE FURNISHED FOR INFORMATIONAL USE ONLY, AND ARE SUBJECT TO CHANGE AT ANY TIME WITHOUT NOTICE, AND SHOULD NOT BE CONSTRUED AS A COMMITMENT BY ASUS. ASUS ASSUMES NO RESPONSIBILITY OR LIABILITY FOR ANY ERRORS OR INACCURACIES THAT MAY APPEAR IN THIS MANUAL, INCLUDING THE PRODUCTS AND SOFTWARE DESCRIBED IN IT.

Products and corporate names appearing in this manual may or may not be registered trademarks or copyrights of their respective companies, and are used only for identification or explanation and to the owners' benefit, without intent to infringe.

# Contents

---

<b>ACCESSORY KIT CONTENTS</b>	<b>2</b>
<b>INSTALLATION GUIDE</b>	<b>3</b>
Remove the Side Panels	4
Install the Power Supply Unit (PSU)	6
Install the Cooler & RAM on the Motherboard	8
Install the I/O Shield	9
Install the Motherboard Unit	10
Attach the Front I/O Connectors	11
Fan Hub Connectivity	12
Install the PCI-E Card	14
Install the 2.5" Drives	17
Install the 3.5" / 2.5" Drives	21
Installation and Maintenance of the Dust Filters	25
<b>ADDITIONAL INFORMATION</b>	<b>26</b>
CPU Cooler Height Limitation	27
Graphics Card Limitation	28
Fan Setup Compatibility	29
Water-cooling Radiator Options	32
Water-cooling Setup Compatibility	33
Integrated Rear Cable Clip	37
<b>SAFETY INFORMATION</b>	<b>39</b>

# Accessory Kit Contents

配備零組件內容物 | 配备組件內容物 | Obsah sady příslušenství | Contenu du kit d'accessoires | Verpackungsinhalt des Zubehörsatzes | Accessori contenuti nel kit | アクセサリーキット内容 | 액세서리 키트 내용물 | Zawartość zestawu akcesoriów | Conteúdo do kit de acessórios | Содержимое комплекта | Contenido del kit de accesorios | Tillbehörsatsens innehåll | Aksesuar Kitinin İçindekiler | محتويات طقم الملحقات | תוכן ערכת האביזרים

## Vertical GPU Kit

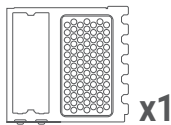

## PSU / 3.5" HDD Screws



## Vertical GPU Kit Thumbscrews



## MB / 2.5" HDD Screws



## MB Standoffs



## Standoff Tool

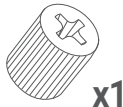

## Cable Ties

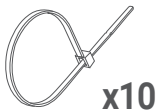



# Installation Guide

安裝指南 | 安裝指南 | Instalační příručka | Guide d'installation |  
Installationsanleitung | Guida all'installazione | 組み立てガイド | 설치 설명서 |  
Instrukcja instalacji | Manual de instalação | Руководство по установке |  
Guía de instalación | Installationsguide | Kurulum Kılavuzu | دليل التركيب |  
מדריך התקנה

# Remove the Side Panels

移除側面板 | 移除側面板 | Sejměte boční panely | Retirer les panneaux latéraux | Entfernen der Seitenwände | Rimuovete i pannelli laterali | サイドパネルを取り外す | 측면 패널 제거 | Zdejmij panele boczne | Remover os painéis laterais | Снятие боковых панелей | Quite los paneles laterales | Ta bort sidopanelerna | Yan Panelleri Çıkarın | أزل اللوحات الجانبية | הסר את הפאנלים הצדדיים



---

## STEP 1

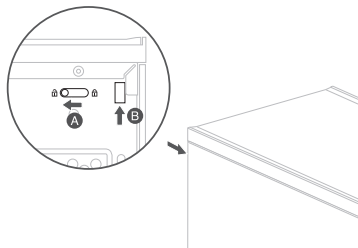

---

## STEP 2

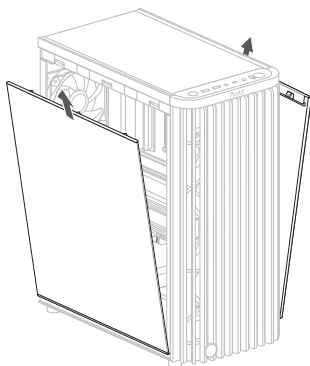

---

STEP 3

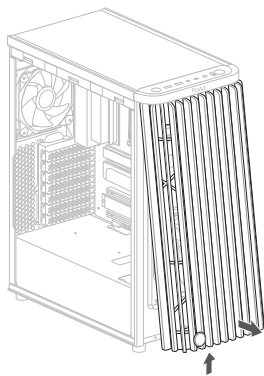

---

STEP 4

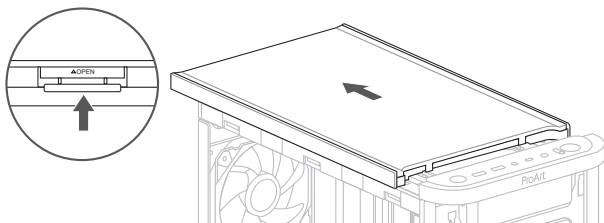

# Install the Power Supply Unit

安裝電源供應器 | 安装电源供应器 | Nainstalujte zdroj napájení (PSU) | Installer le bloc d'alimentation | Installation des Netzteils | Installate l'alimentatore (PSU) | 電源ユニットを取り付ける | 전원 공급장치(PSU) 설치 | Zainstaluj zasilacz (PSU) | Instalar a fonte de alimentação (PSU) | Установка блока питания | Instalar la fuente de alimentación (PSU) | Sätt i strömförsörjningsenheten (PSU) | Güç Kaynağı Ünitesini (PSU) Takın | (PSU) התקן את יחידת ספק הכח | ركب وحدة الإمداد بالطاقة



PSU/3.5" HDD Screws



## STEP 1

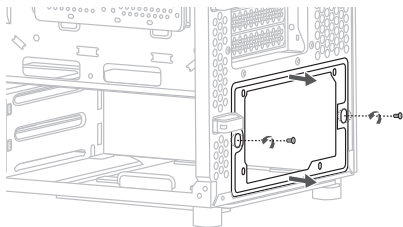

## STEP 2

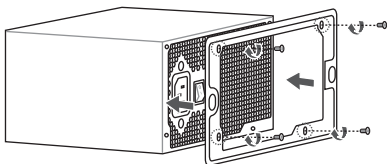

---

STEP 3

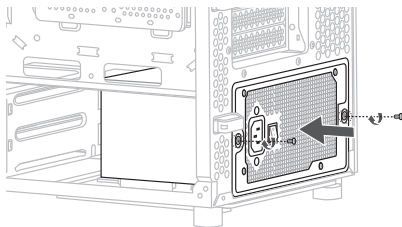

# Install the Cooler & RAM on the Motherboard

安裝主機板散熱器和記憶體 | 安裝主板散熱器和內存 | Nainstalujte chladič a paměť RAM na základní desku | Installer le refroidisseur et la mémoire vive (RAM) sur la carte mère | Installation des Kühlers und der RAM-Module am Motherboard | Installate dissipatore e RAM sulla scheda madre | CPU/クーラー/メモリーをマザーボードに取り付ける | 메인보드에 쿨러 및 RAM 설치 | Zainstaluj element chłodzący i pamięć RAM na płycie głównej | Instalar o dissipador e memória RAM na placa principal | Установка кулера и памяти | Instalar el refrigerador y la memoria RAM en la placa base | Montera kylare och RAM på moderkortet | Soğutucu ve RAM'i Anakarta Takın | התקן את הקירור ויחידות הזיכרון RAM על לוח האם | باللوحة الأم (RAM) ركب المبرد وذاكرة الرام

---

## STEP 1

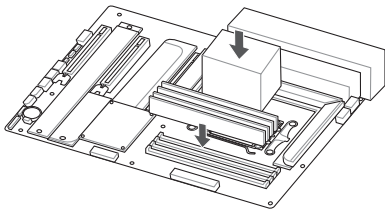

---

## STEP 2

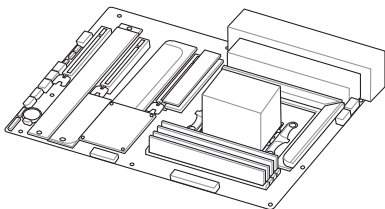

# Install the I/O Shield

安装 I/O 挡板 | 安装 I/O 挡板 | Nainstalujte I/O štít | Installer le cache d'E/S | Installation der E/A-Blende | Installate la mascherina I/O | I/Oシールドを取り付ける | I/O 실드 설치 | Zainstaluj osłonę portów We/Wy | Instalar a tampa de E/S | Установка заглушки разъемов ввода-вывода | Instalar la protección de ES/ | Installera I/O-skölden | G/Ç Koruyucuyu Takın | تركيب غطاء الإدخال / الإخراج | I/O Shield-ה את התקן

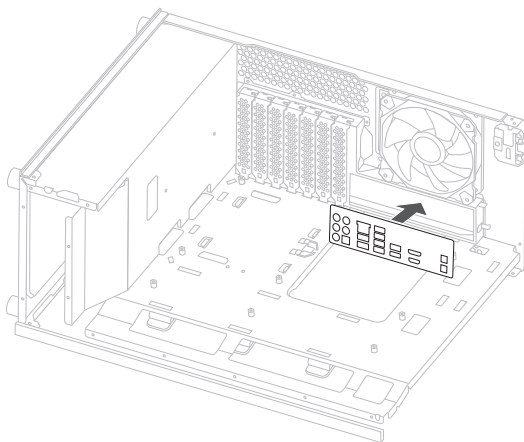

# Install the Motherboard Unit

將主板裝入機殼 | 將主板裝入机箱 | Nainstalujte základní desku | Installer la carte mère | Installation der Motherboard-Baugruppe | Installate la scheda madre | マザーボードを取り付ける | 메인보드 유닛 설치 | Zainstaluj płytę główną | Instalar a placa principal | Установка материнской платы | Instalar la unidad de la placa base | Installera moderkortsenheten | Anakart Ünitesini Takın | رتّب وحدة اللوحة الأم | התקן את לוח האם



MB / 25" HDD Screws

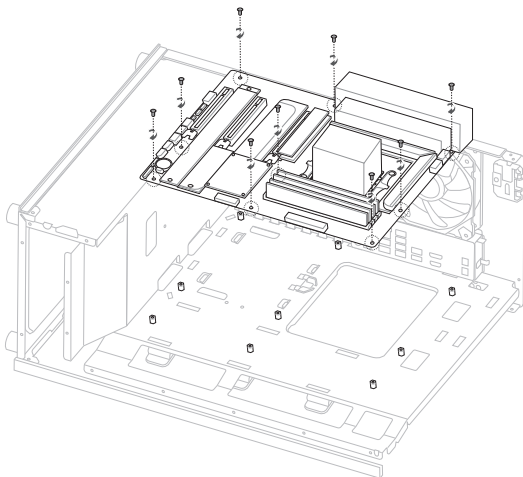

# Attach the Front I/O Connectors

連接前面板 I/O 插孔 | 连接前面板 I/O 插孔 | Připojte přední I/O konektory | Fixer les connecteurs d'E/S avants | Anschließen der E/A-Stecker auf der Frontseite | Collegare i connettori di I/O frontali | フロント I/O コネクタを接続する | 전면 I/O 커넥터 연결 | Zamocuj przednie złącza We/Wy | Encaixar os conectores de E/S frontais | Подключение разъемов передней панели | Acoplar los conectores de E/S frontales | Anslut de främre I/O-kontakterna | Ön G/Ç Konektörlerini Takın | وصّل موصلات الإدخال/الإخراج الأمامية | חבר את מחברי I/O הקדמיים

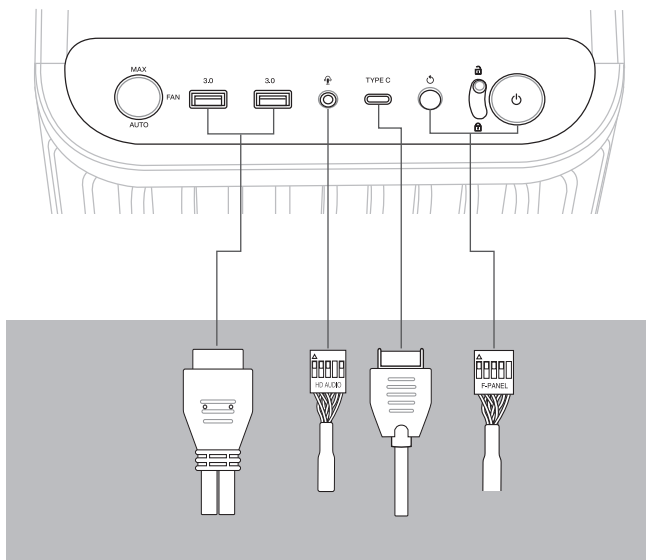

# Fan Hub Connectivity

風扇集線器 | 風扇集線器 | Možnosti připojení rozbočovače ventilátorů | Connectivité du hub pour ventilateur | Verbindungsfähigkeit des Lüfter-Hubs | Connettività dell'hub per ventole | ファンハブの接続方法 | 주소 지정이 팬 허브 연결 | Połączenia koncentratora wentylatorów | Conectividad de hub de ventiladores | Подключение концентратора для вентиляторов | Conectividad del concentrador del ventilador | Hubanslutning för fläkt | Fan Göbeği Bağlanabilirliği | توصيلات المروحة | חיבור מאגר המאווררים |

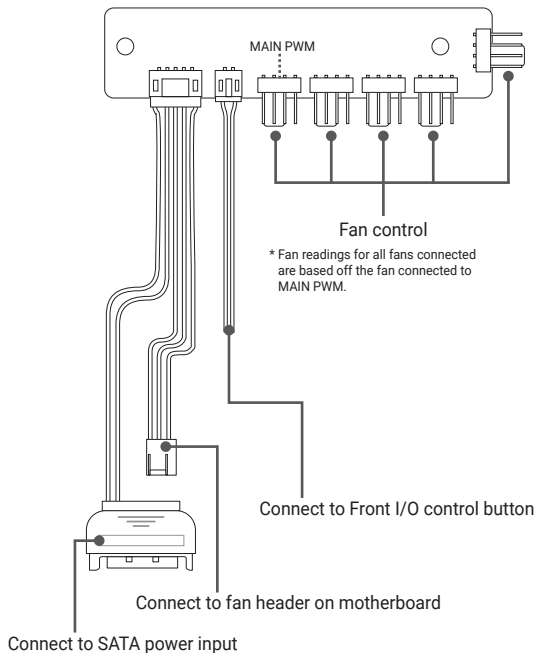

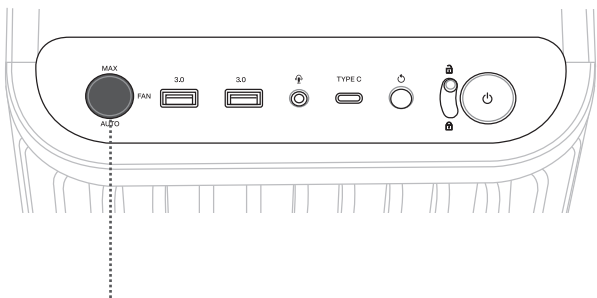

---

<b>MAX</b>	Fans connected to the Fan Control will operate at full speed.
------------	---

---

<b>AUTO</b>	Fans connected to the Fan Control will operate based on the configurations set in BIOS.
-------------	---

---

# Install the PCI-E Card

安裝 PCI-E 卡 | 安裝 PCI-E 卡 | Nainstalujte PCI-E kartu | Installer la carte PCI-E | Installation der PCI-E-Karte | Installate la scheda PCI-E | PCI-Eカードを取り付ける | PCI-E 카드 설치 | Zainstaluj kartę PCI-E | Instalar a placa PCI-E | Установка карты PCI-E | Instalar la tarjeta PCI-E | Installera PCI-E-kortet | PCI-E Kartını Takın | PCI-E بطاقة رَظَب | PCI-E-ה את כרטיס ה-תקן



---

## STEP 1

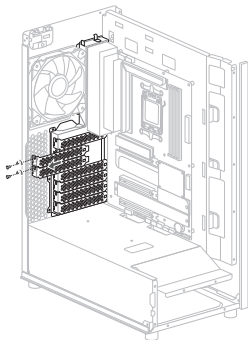

---

## STEP 2

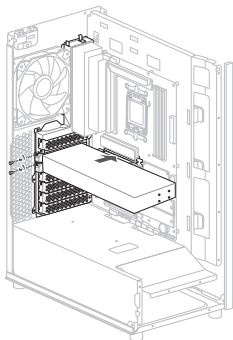

## Installing a GPU in a vertical position

### STEP 1

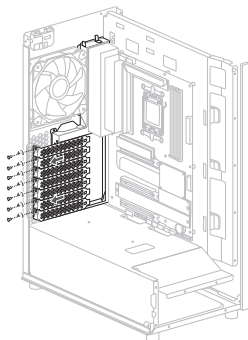
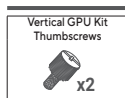
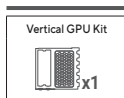

### STEP 2

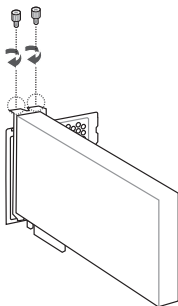

### STEP 3

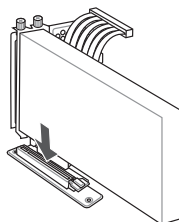

\* Requires riser cable (not included)

---

STEP 4

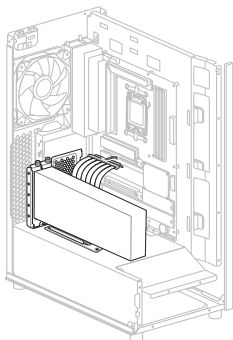

**\* Requires riser cable (not included)**

---

STEP 5

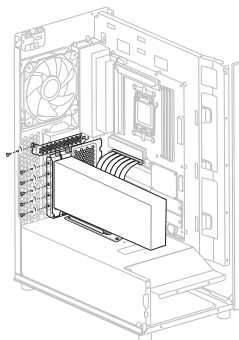

# Install the 2.5" Drives

安裝2.5吋硬碟或固態硬碟 | 安裝 2.5 英寸硬碟或固態硬碟 | Nainstalujte 2,5" jednotky | Installer les lecteurs 2.5" | Installation der 2,5-Zoll-Laufwerke | Installare i drive 2.5" | 2.5インチドライブを取り付ける | 2.5" 드라이브 설치 | Zainstaluj napędy 2,5" | Instalar as unidades de 2,5" | Установка 2,5-дюймового привода | Instalar las unidades de 2,5" | Installera 2,5"-enheterna | 2,5" Sürücüləri Takın | התקנת כונני 2.5 אינץ' | ركب القرص الصلب مقاس 2,5 بوصة



MB / 2.5" HDD Screws



x16

## Configuration 1

### STEP 1

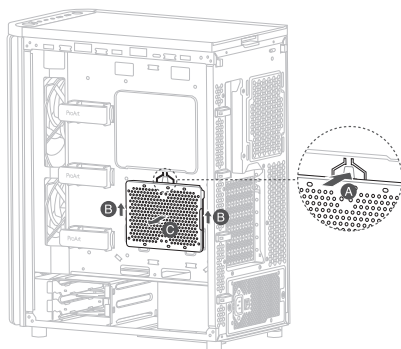

### STEP 2

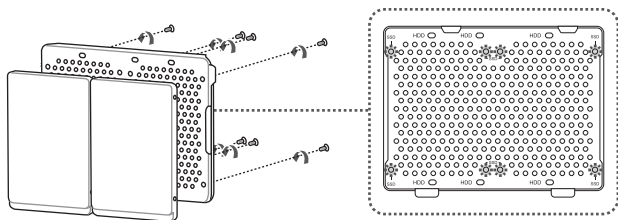

---

STEP 3

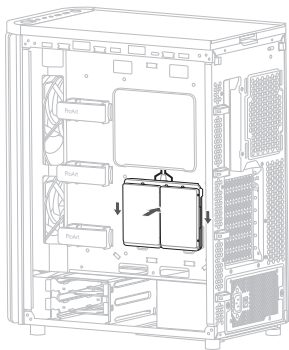

## Configuration 2

---

### STEP 1

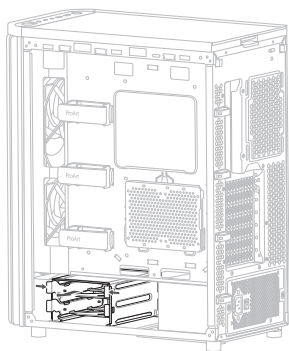

---

### STEP 2

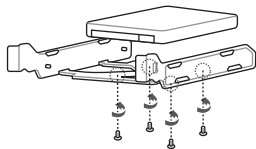

---

### STEP 3

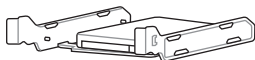

---

STEP 4

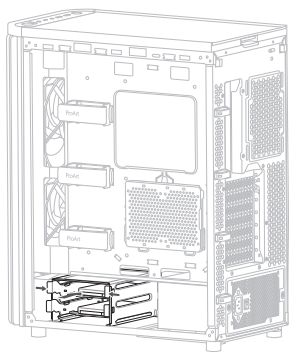

# Install the 3.5" Drives

安裝 3.5 吋硬碟 | 安裝 3.5 英寸硬盤 | Nainstalujte 3,5" jednotky | Installer les lecteurs 3,5" | Installation der 3,5-Zoll-Laufwerke | Installare i drive 3,5" | 3.5 インチ ドライブを取り付ける | 3.5" 드라이브 설치 | Zainstaluj napędy 3,5" | Instalar as unidades de 3,5" | Установка 3,5-дюймового привода | Instalar las unidades de 3,5" | Installera 3,5"-enheterna | 3,5" Sürücülere Takın | تثبيت القرص الصلب بمقاس 3,5 | התקנת כונני 3.5 אינץ'



PSU/3.5" HDD Screws



## Configuration 1

### STEP 1

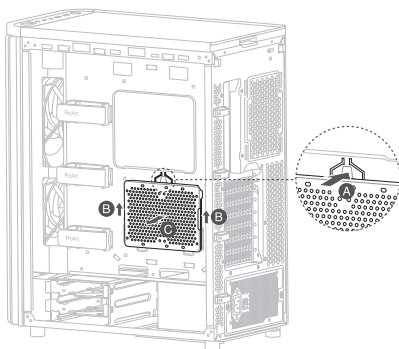

### STEP 2

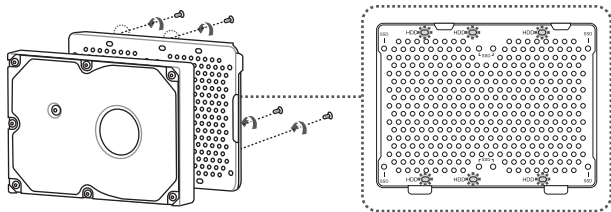

\* Screw hole location will vary between different types of 3.5" drives.

---

STEP 3

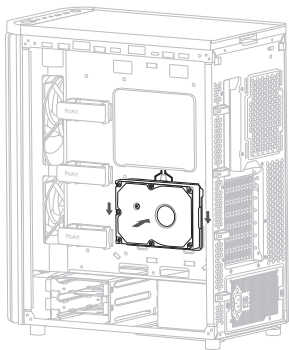

## Configuration 2

### STEP 1

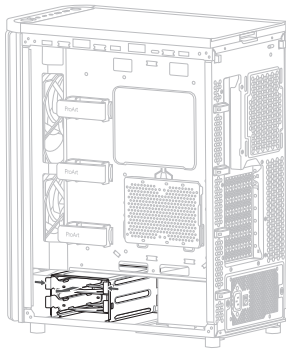

### STEP 2

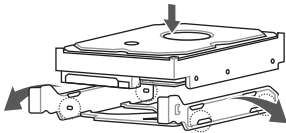

### STEP 3

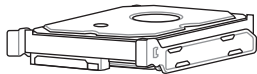

---

STEP 4

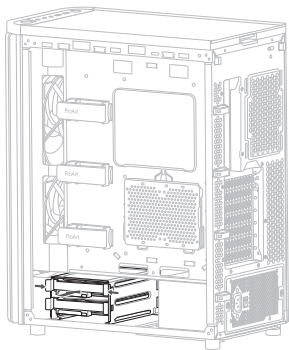

# Installation and Maintenance of the Dust Filters

防塵網安裝及保養 | 防尘网安装及保养 | Instalace a údržba prachových filtrů | Installation et entretien des filtres à poussière | Installation und Wartung der Staubfilter | Installazione e manutenzione dei filtri antipolvere | ダストフィルターの取り付けとメンテナンス | 먼지 필터의 설치 및 유지보수 | Instalacja i konserwacja filtrów antykurzowych | Instalação e manutenção dos filtros de pó | Установка и обслуживание пылевых фильтров | Instalación y mantenimiento de los filtros de polvo | Installation och underhåll av dammfiltren | Toz Filtrelerinin Kurulumu ve Bakımı | התקנה ותחזוק של פילטרי אבק | تركيب وصيانة فلاتر الغبار

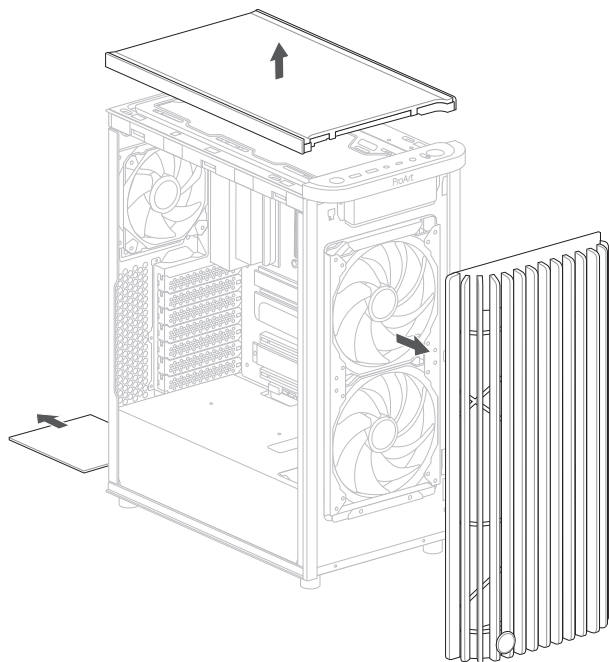



# Additional Information

附加資訊 | 附加信息 | Dodatečné informace | Informations supplémentaires |  
Zusätzliche Informationen | Informazioni addizionali | 追加情報 | 추가 정보 |  
Informacje dodatkowe | Informações adicionais | Дополнительная  
информация | Información adicional | Ytterligere information | Ek Bilgiler |  
מידע נוסף | معلومات إضافية

# CPU Cooler Height Limitation

CPU 散熱器高度限制 | CPU 散热器高度限制 | Výškové omezení chladiče CPU | Limitation de hauteur du refroidisseur pour processeur | Höhenbegrenzung des CPU-Kühlers | Limitazioni di altezza per il dissipatore CPU | CPUクーラーの高さ制限 | CPU 쿨러 높이 제한 | Ograniczenie wysokości elementu chłodzącego CPU | Limitação de altura do dissipador da CPU | Ограничения для высоты процессорного кулера | Limitación de la altura del refrigerador de la CPU | Höjdbegränsning av CPU-kylare | CPU Soğutucu Yükseklik Sınırlaması | מגבלת גובה לקירור עבור מעבד | حد ارتفاع مبرد وحدة المعالجة المركزية

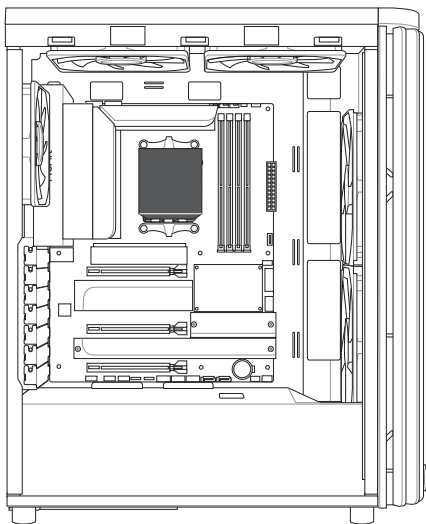

160 mm  
MAX

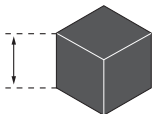

# Graphics Card Limitation

顯示卡長度限制 | 显卡长度限制 | Omezení grafické karty | Limitations de la carte graphique | Beschränkungen der Grafikkarte | Limitazioni per la scheda grafica | グラフィックスカードの長さ制限 | 그래픽 카드 제한 | Ograniczenia karty graficznej | Limitações de placas gráficas | Ограничения для видеокарты | Limitaciones de la tarjeta gráfica | Begränsningar för grafikkort | Grafik Kartı Sınırlamaları | محدود بطاقة الرسومات | מגבלת כרטיס מסך

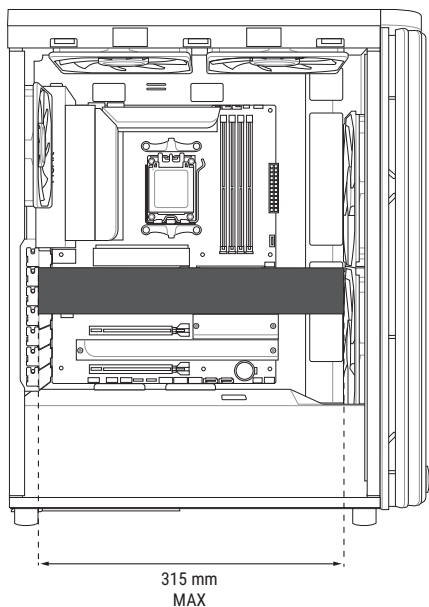

# Fan Setup Compatibility

風扇設定相容性 | 風扇設置兼容性 | Kompatibilita nastavení ventilátoru | Compatibilité d'installation du ventilateur | Kompatibilität der Lüftereinrichtung | Specifiche di installazione per le ventole | ファンの互換性 | 팬 설치 호환성 | Zgodność instalacji wentylatora | Compatibilidade de ventiladores | Установка вентиляторов | Compatibilidad de la configuración del ventilador | Kompatibilitet för fläktinstallation | Fan Kurulumu Uyumluluğu | توافق إعداد المروحة | מערכי מאווררים אפשריים

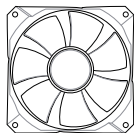
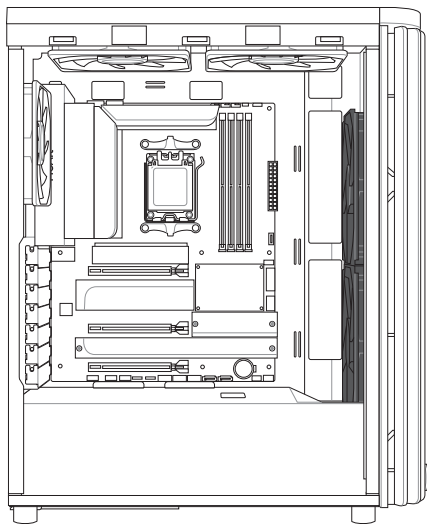

160 mm x 2

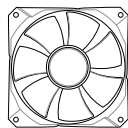
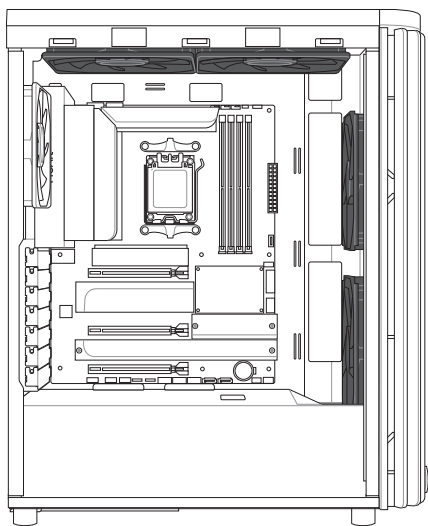

140 mm x 4

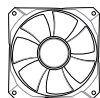
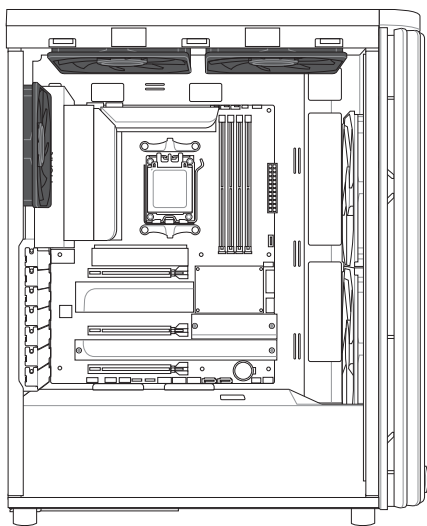

120 mm x 3

# Water-cooling Radiator Options

水冷散熱系統選項 | 水冷散熱系統選項 | Možnosti chladiče vodního chlazení | Options de dissipateur du refroidissement à eau | Optionen der Wasserkühlung | Opzioni per radiatore raffreddamento a liquido | 液冷ラジエーター対応サイズ | 수냉식 라디에이터 옵션 | Opcje instalacji radiatora chłodzonego wodą | Opções de radiadores de refrigeração a água | Радиаторы для жидкостного охлаждения | Opciones del radiador de refrigeración por agua | Alternativ för vattenkyllningselement | Su Soğutma Radyatörü Seçenekleri | خيارات رادياتور تبريد الماء | אפשרויות התקנה לרדיאטורים

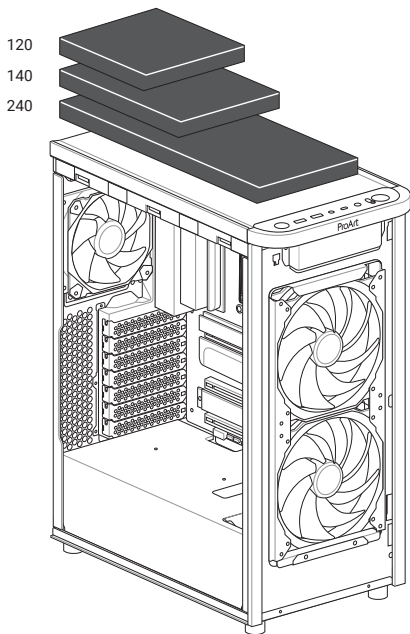

# Water-cooling Setup Compatibility

水冷散熱系統設定相容性 | 水冷散熱系統設置相容性 | Kompatibilita nastavení vodního chlazení | Compatibilité d'installation du refroidissement à eau | Kompatibilität der Wasserkühlungseinrichtung | Specifiche di installazione raffreddamento a liquido | ラジエーターとファンの制限 | 수냉식 설치 호환성 | Zgodność instalacji chłodzenia wodą | Compatibilidade de radiadores de refrigeração a água | Установка системы жидкостного охлаждения | Compatibilidad de la configuración de refrigeración por agua | Kompatibilitet för vattenkylningsinstallation | Su Soğutma Kurulumu Uyumluluğu | توافق إعداد تبريد المياه | מערכי קירור נוזלי מתאימים

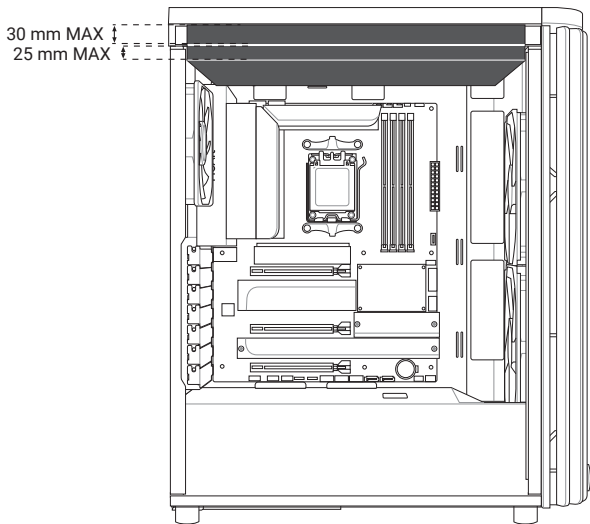

---

STEP 1

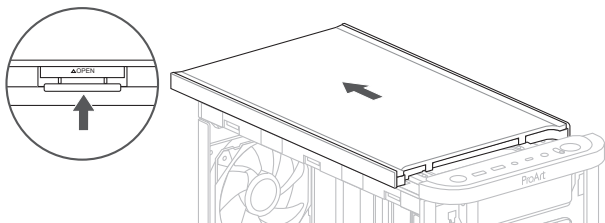

---

STEP 2

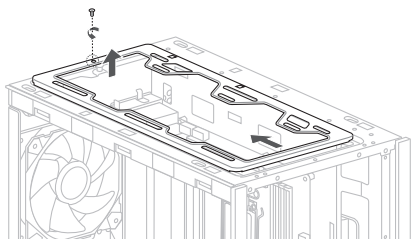

---

STEP 3

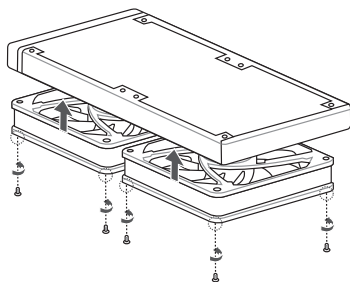

---

STEP 4

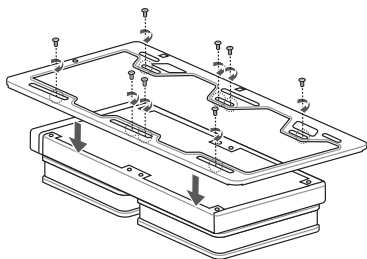

---

STEP 5

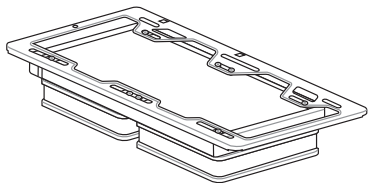

---

STEP 6

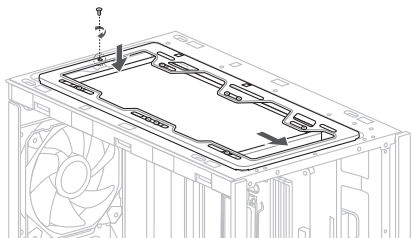

# Integrated Rear Cable Clip

後背板理線卡扣 | 后背板理线卡扣 | Svorka zadního kabelu | Serre-câble arrière | Kabelklemme auf der Rückseite | Fermacavi posteriore | リアケーブルクリップ | 후면 케이블 클립 | Tylny zacisk kablowy | Presilha do Cabo Traseiro | Специальные зажимы на задней панели | Abrazadera de cables posterior | Bakre kabeklämma | Arka Kablo Klipsi | תפס כבלים אחורי | مشبك الكبل الخلفي

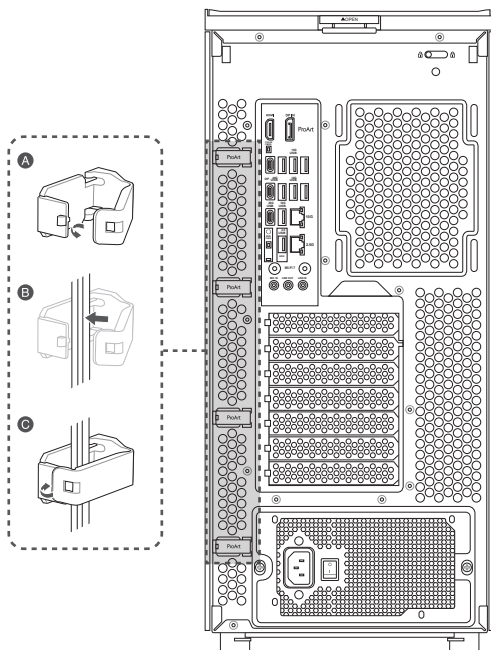





# Safety Information

安規資訊 | 安規信息 | Bezpečnostní informace | Consignes de sécurité |  
Sicherheitsinformationen | Informazioni sulla sicurezza | 安全性情報 | 안전  
정보 | Informacje dotyczące bezpieczeństwa | Informações de segurança |  
Информация о правилах безопасности | Información de seguridad |  
Säkerhetsinformation | Güvenlik Bilgileri | معلومات السلامة | מידע בטיחותי

## Declaration of compliance for product environmental regulation

ASUS follows the green design concept to design and manufacture our products, and makes sure that each stage of the product life cycle of ASUS product is in line with global environmental regulations. In addition, ASUS disclose the relevant information based on regulation requirements. Please refer to <https://esg.asus.com/Compliance.htm> for information disclosure based on regulation requirements ASUS is complied with:

### EU RoHS

This product complies with the EU RoHS Directive. For more details, see <https://esg.asus.com/Compliance.htm>

### India RoHS

This product complies with the "India E-Waste (Management) Rules, 2016" and prohibits use of lead, mercury, hexavalent chromium, polybrominated biphenyls (PBBs) and polybrominated diphenyl ethers (PBDEs) in concentrations exceeding 0.1% by weight in homogenous materials and 0.01% by weight in homogenous materials for cadmium, except for the exemptions listed in Schedule II of the Rule.

### Vietnam RoHS

ASUS products sold in Vietnam, on or after September 23, 2011, meet the requirements of the Vietnam Circular 30/2011/TT-BCT.

Các sản phẩm ASUS bán tại Việt Nam, vào ngày 23 tháng 9 năm 2011 trở về sau, đều phải đáp ứng các yêu cầu của Thông tư 30/2011/TT-BCT của Việt Nam.

### Türkiye RoHS

AEEE Yönetmeliğine Uygundur

### ASUS Recycling/Takeback Services

ASUS recycling and takeback programs come from our commitment to the highest standards for protecting our environment. We believe in providing solutions for you to be able to responsibly recycle our products, batteries, other components as well as the packaging materials. Please go to <https://esg.asus.com/en/Takeback.htm> for detailed recycling information in different regions.

## Australia statement notice

From 1 January 2012 updated warranties apply to all ASUS products, consistent with the Australian Consumer Law. For the latest product warranty details please visit <https://www.asus.com/support/>. Our goods come with guarantees that cannot be excluded under the Australian Consumer Law. You are entitled to a replacement or refund for a major failure and compensation for any other reasonably foreseeable loss or damage. You are also entitled to have the goods repaired or replaced if the goods fail to be of acceptable quality and the failure does not amount to a major failure. If you require assistance please call ASUS Customer Service 1300 2787 88 or visit us at <https://www.asus.com/support/>.

## REACH

Complying with the REACH (Registration, Evaluation, Authorisation, and Restriction of Chemicals) regulatory framework, we published the chemical substances in our products at ASUS REACH website at <https://esg.asus.com/Compliance.htm>. (English)

謹遵守REACH(Registration, Evaluation, Authorisation, and Restriction of Chemicals)管理規範。我們會將產品中的化學物質公告在華碩REACH網站。詳細請參考<https://esg.asus.com/Compliance.htm>。(繁體中文)

謹遵守REACH(Registration, Evaluation, Authorisation, and Restriction of Chemicals)管理規範。我们会将产品中的化学物质公告在华硕REACH网站。详细请参考<https://esg.asus.com/Compliance.htm>。(简体中文)

V rámci shody s regulaturní platformou REACH (Registration, Evaluation, Authorisation, and Restriction of Chemicals (registrace, hodnocení, povolování a omezování chemických látek)) byl zveřejněn seznam chemických látek přítomných v našich produktech na webu ASUS REACH na adrese <https://esg.asus.com/Compliance.htm>. (Čeština)

Conforme avec le Règlement REACH (Enregistrement, Évaluation, Autorisation et Restriction des produits chimiques), nous avons publié la liste des substances chimiques utilisées dans nos produits sur le site Web ASUS REACH à l'adresse <https://esg.asus.com/Compliance.htm>. (Français)

Die rechtliche Rahmenbedingungen für REACH (Registration, Evaluation, Authorisation, and Restriction of Chemicals) erfüllend, veröffentlichen wir die chemischen Substanzen in unseren Produkten auf unserer ASUS REACH-Webseite unter <https://esg.asus.com/Compliance.htm>. (Deutsch)

Nel rispetto del regolamento REACH (Registration, Evaluation, Authorisation, and Restriction of Chemicals), le sostanze chimiche contenute nei prodotti ASUS sono state pubblicate nel sito web ASUS, alla pagina: <https://esg.asus.com/Compliance.htm>. (Italiano)

REACH (Registration, Evaluation, Authorisation, and Restriction of Chemicals)規則の基準を満たすため、ASUSはREACH専用サイトで弊社製品に含まれる化学物質を公開しております。  
<https://esg.asus.com/Compliance.htm>. (日本語)

REACH (Registration, Evaluation, Authorisation, and Restriction of Chemicals) 등록, 평가, 승인 및 화학물질규제) 규제 기준을 준수하여 ASUS REACH 웹사이트 <https://esg.asus.com/Compliance.htm> 에 당사 제품에사용된 화학 물질을 게시했습니다. (한국어)

Zgodnie z rozporządzeniem REACH (Rejestracja, ocena, autoryzacja i ograniczenie środków chemicznych), publikujemy informacje o środkach chemicznych w naszych produktach, na stronie internetowej ASUS REACH pod adresem <https://esg.asus.com/Compliance.htm> (Polski)

Cumprindo o quadro regulamentar REACH (Registo, Avaliação, Autorização e Restrição dos Produtos Químicos), divulgamos as substâncias químicas incluídas nos nossos produtos no Web site ASUS REACH em <https://esg.asus.com/Compliance.htm>. (Português)

Согласно регламенту ЕС REACH (Registration, Evaluation, Authorization, and Restriction of Chemicals – Регистрация, Оценка, Разрешения и Ограничения на использование Химических веществ), на сайте ASUS REACH размещен список химических веществ содержащихся в наших продуктах: <https://esg.asus.com/Compliance.htm>. (Русский)

En cumplimiento del marco reglamentario REACH (registro, evaluación, autorización y restricción de productos químicos), hemos publicado las sustancias que contienen nuestros productos a través del sitio web ASUS REACH, al que puede acceder a través de la dirección <https://esg.asus.com/Compliance.htm>. (Español)

Uppfyller REACH (Registration, Evaluation, Authorization, and Restriction of Chemicals (Registrering, Värdering, Behörighet och Begränsning)) reglerande regelverk, vi publicerar de kemiska substanserna i våra produkter på ASUS REACH webbsida på <https://esg.asus.com/Compliance.htm>. (Svenska)

REACH (Kimyasalların Kayıt Altına Alınması, Değerlendirilmesi, Ruhsatlandırılması ve Sınırlandırılması) düzenleyici çerçevesine uygun olarak, ürünlerimizdeki kimyasal maddeleri <https://esg.asus.com/Compliance.htm> adresindeki ASUS REACH websitesinde yayınlamaktayız. (Türkçe)

امتثالاً لإطار العمل التنظيمي الخاص بتسجيل المواد الكيميائية وتقييمها والتصديق عليها وتقيدها استخدامها (REACH)، قمنا بنشر المواد الكيميائية المستخدمة في منتجاتنا على موقع ASUS REACH على العنوان <https://esg.asus.com/Compliance.htm> (عربي)



电子电气产品有害物质限制使用标识：图中之数字为产品之环保使用期限。仅指电子电气产品中含有的有害物质不致发生外泄或突变，从而对环境造成污染或对人身、财产造成严重损害的期限。

有害物质名称及含量说明标示：

部件名称	有害物质					
	铅 (Pb)	汞 (Hg)	镉 (Cd)	六价铬 (Cr <sup>VI</sup> )	多溴联苯(PBB)	多溴二苯醚(PBDE)
机箱组	○	○	○	○	○	○
面板组	○	○	○	○	○	○
I/O模组	○	○	○	○	○	○
风扇	○	○	○	○	○	○
零件包	○	○	○	○	○	○

本表格依据 SJ/T 11364 的规定编制。  
 ○：表示该有害物质在该部件所有均质材料中的含量均在 GB/T 26572 规定的限量要求以下。  
 ×：表示该有害物质至少在该部件的某一均质材料中的含量超出 GB/T 26572 规定的限量要求，然该部件仍符合欧盟指令 2011/65/EU 的规范。  
 备注：此产品所标示之环保使用期限，系指在一般正常使用状况下。

## France sorting and recycling information



FR

Cet appareil  
et ses accessoires  
se recyclent

REPRISE  
À LA LIVRAISON



À DÉPOSER  
EN MAGASIN



À DÉPOSER  
EN DÉCHÈTERIE



Points de collecte sur [www.quefairedemesdechets.fr](http://www.quefairedemesdechets.fr)  
 Privilégiez la réparation ou le don de votre appareil !

## Safety Precautions

Accessories that came with this product have been designed and verified for the use in connection with this product. Never use accessories for other products to prevent the risk of electric shock or fire.

## 安全上のご注意

付属品は当該専用用品です。他の機器には使用しないでください。機器の破損もしくは、火災や感電の原因となることがあります。



# ProArt

Power Up Your Imagination

